

**The Philadelphia Parking Authority  
701 Market Street, Suite 5400  
Philadelphia, PA 19106**

**Bid No. 22-14  
General Construction at 6 East Oregon Avenue  
Addendum Two**

To: See Email Distribution List

From: Mary Wheeler  
Director of Procurement

Date: June 08, 2022

No Pages: 22

This addendum is issued on June 08, 2022 prior to the bid due date to add, delete, modify, clarify and/or to respond to questions submitted by prospective bidders regarding the work included in the above referenced solicitation.

**QUESTIONS**

1. **Question:** Please provide a specification for the asphalt seal coating/crack repair being bid as Alternate 1.

**Response:** Use a coal tar pitch emulsion prepared from a high temperature, coke-oven tar conforming to ASTM D 490, Standard Specification for Road Tar, Grades RT-11 or RT-12. Petroleum tar and oil and water gas tars shall not be used.

Copolymer latex rubber will be added to the coal tar pitch emulsion. This material will contain 51-70 parts butadiene and 30-40 parts acrylonitrile. The minimum solid content will be 40%, particle size will be less than 90 nanoyards, and silicone content will be 4% rubber content.

2. **Question:** Please clarify extent of line striping and symbols included in the work, will existing lines have to be eradicated or otherwise coated?

**Response:** Existing line striping is to be eradicated if sealcoating alternate is not selected.

3. **Question:** Detail 2 on A-301 indicates that the paving base in Oregon Ave along the curb replacement is 2A modified. Philadelphia typically has a concrete base. Please confirm the paving section.

**Response:** The paving base is concrete.

4. **Question:** Please confirm that the owner supplied fence material includes all accessories, that is, pipe, fabric, rails, brackets, couplings, nuts and bolts, tension bars, turnbuckles, razor wire, etc.

**Response:** It is believed that all the accessories are included.

5. **Question:** Please confirm that all electrical work and security work in the trailer is by others, and not to be included in the GC scope.

**Response:** That is correct. Electrical work and security work are by others and not included in the GC scope.

- 6. Question:** Please confirm that the electrical contractor is supplying and installing the light pole and switchgear foundations.  
**Response:** That is correct. The electrical contractor will be supplying and installing the light pole and switchgear foundations.
- 7. Question:** Please confirm that there is no plumbing to be provided by the GC for the restroom trailer. **Response:** That is correct.
- 8. Question:** Please confirm that the finish on the ramps is the wood deck, that is, no nonslip material.  
**Response:** That is correct.
- 9. Question:** Please confirm if a handrail will be installed on both sides of the ramps and stairs. Or will the detail on 5/A-101 be used for the ramps and stairs, if a handrail is needed, please provide a detail.  
**Response:** Handrails will be required on both sides of the ramps and stairs. See revised sheet A-101 attached.
- 10. Question:** Please confirm that all HVAC work in the trailer(s) will be performed on an hourly basis.  
**Response:** Provide an allowance for the Modifications to Registers line item on the Bid form based on the hourly rate identified in the Unit Cost line-item D.
- 11. Question:** The bollards shown on the plans add up to a count of 35. The bid item states 26 ea, please confirm quantity.  
**Response:** This has been revised to 37. See revised Bid Form attached.
- 12. Question:** Are the shop drawings available for the three planned trailers and guard booth?  
**Response:** Not currently.
- 13. Question:** Will the deck framing be independent of the trailers or will the ledger boards be attached to the trailers.  
**Response:** Deck will be framed independently from the trailers.
- 14. Question:** Please confirm that the 12" deck overhang only occurs at railing and the areas parallel with the trailers can be framed with a ledger board against the trailers.  
**Response:** See response to question 13.
- 15. Question:** Detail 4/A-201 shows a latch set for the new Armortex door. Security plan shows a card reader for this door, which typically requires more than a latchset. Is any other hardware (beside Hinges) needed for this door?  
**Response:** Provide "Store Lock" lever set. (Key in either lever locks or unlocks both levers)

**END OF ADDENDUM TWO**

SECTION 004100 - BID FORM

PART 1 - GENERAL

1.01 PHILADELPHIA PARKING AUTHORITY DOCUMENT

- A. The required executed bid form checklist and bid form are attached following this page.

1.02 RELATED REQUIREMENTS

- A. Section 00 21 13 - Instructions to Bidders.
- B. Section 00 73 00 - Supplementary Conditions.
- C. Section 01 21 00 - Allowances.
- D. Section 01 22 00 - Unit Prices.

PART 2 - PRODUCTS (NOT USED)

PART 3 - EXECUTION (NOT USED)

END OF SECTION 004100

\_\_\_\_\_  
(Name of Bidder)

**BID FORM CHECKLIST**

The following Proposal is hereby made as a "Stipulated Sum Bid No 22-14" from:

\_\_\_\_\_  
(Bidder)

\_\_\_\_\_  
(Address)

\_\_\_\_\_  
(City, State, Zip)

\_\_\_\_\_  
(Contact Person) \_\_\_\_\_  
(Phone Number)

**SUBMISSION REQUIREMENTS**

Items are to be submitted with Bid IN THE FOLLOWING ORDER:

Initial  
each  
required  
entry

<input type="checkbox"/>	Bid Form – Fully executed – Section 00 41 00. Quantity (17) pages including this cover.	
<input type="checkbox"/>	List of Subcontractors and Material Suppliers – Section 00 43 36	
<input type="checkbox"/>	Schedule for Participation by Small and Diverse Businesses (See Section 00 43 40 and Article 18 of the Instructions to Bidders).	
<input type="checkbox"/>	If full compliance for participation with Small and Diverse Businesses cannot be attained submit a Request for Waiver / Reduction of Participation Form (See Section 00 43 45 and Article 19 of the Instructions for Bidders)	
<input type="checkbox"/>	Sample Certificate of Insurance or Statement of Insurance indicating that insurance requirements can be met in accordance with Section 00 73 00 - Supplementary Conditions.	
<input type="checkbox"/>	Submission of Bid Security prepared in accordance with Article 13 of the Instructions to Bidders.	
<input type="checkbox"/>	Submission of Consent of Surety for Performance, Labor, and Material Payment Bonds in accordance with Article 14 of the Instructions to Bidders.	
<input type="checkbox"/>	Evidence of participating in a State Certified Apprenticeship Program as requested on Bid Form Paragraph 14.16.	
<input type="checkbox"/>	Financial Statements, for the last three (3) years. The Financial Statements shall be attached only to the original copy of the Bid Form or in a separate envelope marked "CONFIDENTIAL."	
<input type="checkbox"/>	List of completed similar projects requested on Bid Form Paragraph 14.10.	
<input type="checkbox"/>	List of pending similar projects requested on Bid Form Paragraph 14.11.	
<input type="checkbox"/>	List of equipment available to perform proposed work requested on Bid Form Paragraph 14.14.	

\_\_\_\_\_  
(Name of Bidder)

**BID FORM**

1.0 The following proposal is hereby made to:

The Philadelphia Parking Authority  
Attention: Mary Wheeler, Director of Procurement  
701 Market Street, Suite 5400  
Philadelphia, PA 19106

2.0 LUMP SUM CONTRACT PRICE FOR THE WORK: GENERAL CONSTRUCTION at 6 EAST OREGON AVENUE

Pursuant to and in compliance with the Invitation to Bid and the Instruction to Bidders relating thereto, The Undersigned hereby proposes and agrees to furnish all the necessary labor, materials, equipment, facilities, tools and services necessary to perform and complete the whole of the Construction work described in the Contract Documents for General Construction at 6 East Oregon Avenue, and all appurtenant work in accordance with the Drawings, Specifications, General and Supplementary Conditions, Special Contract Requirements, and other Contract Documents, and according to any additional explanations that may be furnished by the Philadelphia Parking Authority for the following stipulated amount:

SPEC	DESCRIPTION	QTY	UNIT	UNIT COST	COST
<b>1-Procurement and Contracting Requirements/General Requirements</b>					
006113	Performance and Payment Bond Form	1	LS		
017113	Mobilization/General Conditions	1	LS		
Subtotal					
<b>2-Existing Conditions</b>					
024118	Selective Site Demolition	4,700	SF		
Subtotal					
<b>5-Metals</b>					
055000	Metal Fabrications, Bollards	<b>37</b>	EA		
Subtotal					
<b>6-Woods, Plastics, and Composites</b>					
061533	Wood Patio Decking (including foundations)	1,185	SF		
Subtotal					
<b>8-Openings</b>					
081113	Hollow Metal Doors and Frames, Bullet Resistant	<b>1</b>	EA		
081113.01	Bullet Resistant Teller Windows w/ Countertops	6	EA		
Subtotal					

\_\_\_\_\_  
(Name of Bidder)

9-Finishes					
092900	Gypsum Board	<b>590</b>	SF		
092910	Bullet Resistant Sheathing, Level 3	<b>590</b>	SF		
096513	Resilient Base	<b>70</b>	LF		
099123	Interior Painting	<b>600</b>	SF		
Subtotal					
10-Specialties					
101400	Signage	3	EA		
Subtotal					
23-Heating, Ventilating, and Air Conditioning (HVAC)					
230000	Modifications to Registers	1	LS		
31-Earthwork					
311001	Site Preparation	2,750	SF		
Subtotal					
32-Exterior Improvements					
321216	Asphalt Paving	10	SY		
321313	Concrete Paving	4,700	SF		
321373	Concrete Paving Joint Sealants	260	LF		
321713	Parking Bumpers (Wheel Stops)	50	EA		
321723	Pavement Markings	272	EA		
323113.1	Chain Link Fences and Gates Perimeter Owner Provided Contractor Installed	1,966	LF		
323113.2	Chain Link Fences and Gates Interior Contractor Supplied and Installed	500	LF		
323119	Decorative Metal Fence Owner Provided Contractor Installed	260	LF		
Subtotal					

LUMP SUM CONTRACT PRICE: \_\_\_\_\_ (in words)

Dollars \$\$: \_\_\_\_\_ (in numbers)

\_\_\_\_\_  
(Name of Bidder)

2.1 UNIT COSTS:

The Philadelphia Parking Authority reserves the right to choose certain other unit price bid items as described below:

- A. Remove and proper disposal of unsuitable, unclassified materials and replace with approved compacted fill: \$ \_\_\_\_\_ per cubic yard
  
- B. Rock excavation and replacement with satisfactory soil material:
  - a. Hammered, Bulk: \$ \_\_\_\_\_ per cubic yard
  
  - b. Hammered, Trench: \$ \_\_\_\_\_ per cubic yard
  
- C. 2A Modified Crushed Stone: \$ \_\_\_\_\_ per cubic yard
  
- D. Hourly rate for HVAC work: \$ \_\_\_\_\_ per hour

2.2 ALTERNATES

The Philadelphia Parking Authority reserves the right to choose certain alternate bid items as described below:

- 1. Alternate No. 01: Asphalt Seal Coating:
  - a. 146,000 SF: \$ \_\_\_\_\_

\_\_\_\_\_  
(Name of Bidder)

3. Knowledge of Contract Documents

Bid No. 22-14 General Construction at 6 East Oregon Avenue, including Notice to Bidders, Instructions to Bidders, General and Supplementary Conditions of the Contract and Addenda, if any, (hereinafter collectively referred to as the "Bidding Documents") as prepared by the Philadelphia Parking Authority and on file in the office of the Philadelphia Parking Authority at 701 Market Street, Suite 5400, Philadelphia, PA, hereby proposes to complete all work as specified or indicated in the Bidding Documents for the Stipulated Amount and within the Contract Time indicated in this bid.

\_\_\_\_\_  
Authorized Signature

\_\_\_\_\_  
Print Name of Signer

\_\_\_\_\_  
Title of Signer

\_\_\_\_\_  
Date

4. Site Inspection Statement

The Undersigned has visited and examined the site(s) involved for General Construction at 6 East Oregon Avenue, as required in the Instructions to Bidders. As a consequence of this inspection, the undersigned Contractor has knowledge of local conditions and is fully cognizant of the circumstances and conditions that may affect the prosecution and completion of the work and the cost thereof.

The site inspection(s) took place prior to the submission of the bid.

\_\_\_\_\_  
Authorized Signature

\_\_\_\_\_  
Print Name of Signer

\_\_\_\_\_  
Title of Signer

\_\_\_\_\_  
Date of Inspection



\_\_\_\_\_  
(Name of Bidder)

5. Execution of Agreement and Furnishing Bonds

Within ten (10) calendar days after receipt of written Notice of Award of Contract, the Contractor agrees to execute and deliver the form of Agreement included as one of the Contract Documents, and to furnish a Performance Bond in an amount equal to 100% of the Contract Amount and a Labor and Material Payment Bond in an amount equal to 100% of the Contract Amount.

\_\_\_\_\_  
Authorized Signature

\_\_\_\_\_  
Print Name of Signer

\_\_\_\_\_  
Title of Signer

\_\_\_\_\_  
Date

6. Addenda

The Undersigned hereby acknowledges receipt of the following Addenda:

<u>Addendum No.</u>	<u>Dated</u>	<u>No. of Pages</u>	<u>Signature</u>
---------------------	--------------	---------------------	------------------

_____	_____	_____	_____
_____	_____	_____	_____
_____	_____	_____	_____

7. Contract Time

If awarded the Contract, the Undersigned agrees to complete the entire work in One hundred twenty (120) Calendar Days commencing from the date of Notice to Proceed. If the Contractor fails to complete the project in the required time, the Contractor shall pay to the Philadelphia Parking Authority five-hundred dollars (\$500.00) per calendar day as damages for delay commencing with the (120 plus one) day.

\_\_\_\_\_  
Authorized Signature

\_\_\_\_\_  
Print Name of Signer

\_\_\_\_\_  
Title of Signer

\_\_\_\_\_  
Date

\_\_\_\_\_  
(Name of Bidder)

8. Work Conditions

The Undersigned is cognizant of the fact that other contractors may be concurrently performing work in the same areas and that the Undersigned is responsible for providing full and uninterrupted access to other contractors performing work at all times.

\_\_\_\_\_  
Authorized Signature

\_\_\_\_\_  
Print Name of Signer

\_\_\_\_\_  
Title of Signer

\_\_\_\_\_  
Date

9. Submission of Plans and Schedules

Within five (5) days after receipt of written Notice to Proceed, based upon the Undersigned's knowledge and review of the Bidding Documents (as set forth in Paragraph 3) and the Contract Time (as set forth in Paragraph 7), the Undersigned agree to execute and submit to the Philadelphia Parking Authority the following "Plans and Schedules," which shall thereafter constitute Contract Documents:

- 9.1 A Construction Management Plan which should include all phasing, scheduling, and submissions of all required documents to allow for timely execution of the Contract per the Owner's overall project documents and milestone schedule and include workforce projection and anticipated schedule of payments for the entire project.
- 9.2 A Detailed Project Schedule which should be a complete Critical Path Method schedule indicating all tasks involved in order to complete the project.
- 9.3 A Quality Control Plan which should designate the Undersigned's Quality Control Manager, who will be responsible for communicating with Philadelphia Parking Authority and its agents with respect to all quality control issues throughout the project. The contractor must submit the Contractor's Quality Control Plan. The plan must include reference to all over site associations referred to in the Contract Documents as they pertain to Quality Control and pertinent Quality Control forms (example: Welding Certificate and Reference Specifications) in order to execute all work as intended in the Bid Documents.

\_\_\_\_\_  
Authorized Signature

\_\_\_\_\_  
Print Name of Signer

\_\_\_\_\_  
Title of Signer

\_\_\_\_\_  
Date

\_\_\_\_\_  
(Name of Bidder)

10. Authority's Rights Reserved

The Undersigned understands that the Philadelphia Parking Authority reserves the right to withdraw and cancel this Invitation to Bid prior to opening of bids, to reject any or all bids after bids are opened, or to waive any formality or technicality in any Bid; in the best interest of the Philadelphia Parking Authority. Furthermore, the Philadelphia Parking Authority reserves the right to delete portions of any work and award a contract for the remaining balance of work included in the Contract Documents.

\_\_\_\_\_  
Authorized Signature

\_\_\_\_\_  
Print Name of Signer

\_\_\_\_\_  
Title of Signer

\_\_\_\_\_  
Date

11. Bid Submission Acknowledgement

The above proposal is hereby respectfully submitted by: *(Complete Section 11.1 or 11.2).*

11.1 If bid is by a corporation, form must include the date and be signed here by (a) President or Vice President, and (b) Secretary, Assistant Secretary, Treasurer, Assistant Treasurer, or Officer and (c) a corporate seal must be affixed. If this form is not so signed, a corporate resolution authorizing form of execution must be attached to this bid.

\_\_\_\_\_  
Signature

\_\_\_\_\_  
Typed or Printed Name

\_\_\_\_\_  
Title

\_\_\_\_\_  
Business Name of Bidder

\_\_\_\_\_  
Street Address

\_\_\_\_\_  
City/State/ZIP Code

\_\_\_\_\_  
Telephone Number

\_\_\_\_\_  
Signature

\_\_\_\_\_  
Typed or Printed Name

\_\_\_\_\_  
Title

\_\_\_\_\_  
Date

\_\_\_\_\_  
(Name of Bidder)

11.2 If bid is by a business entity other than a corporation form must be dated and signed here:

\_\_\_\_\_  
Authorized Signature

\_\_\_\_\_  
Business Name of Bidder

\_\_\_\_\_  
Typed or Printed Name

\_\_\_\_\_  
Street Address

\_\_\_\_\_  
Title

\_\_\_\_\_  
City/State/ ZIP Code

\_\_\_\_\_  
Date

\_\_\_\_\_  
Telephone Number

\_\_\_\_\_  
Type of Entity

\_\_\_\_\_  
(Name of Bidder)

12. Affidavit of Non-Collusion:

State of: \_\_\_\_\_

Bid No. \_\_\_\_\_

County of: \_\_\_\_\_

I state that I am \_\_\_\_\_ (Title) of \_\_\_\_\_ (name of my organization) and that I am authorized to make this affidavit on behalf of my firm, and its owners, directors, members and officers. I am the person responsible in my firm for the price(s) and the amount of this proposal and I have placed my signature below.

I state that:

- (1) The price(s) and amount of this proposal have been arrived at independently and without consultation, communication or agreement with any other contractor, offeror, or potential offeror.
- (2) Neither the price(s) nor the amount of this proposal, and neither the terms nor the approximate price(s) nor approximate amount of this proposal, have been disclosed to any other firm or person who is a bidder or potential proposal, and they will not be disclosed before proposal opening.
- (3) No attempt has been made or will be made to induce any firm or person to refrain from submitting a proposal in response to this solicitation, or to submit a proposal higher than this proposal, or to submit any intentionally high or noncompetitive proposal or other form of complementary proposal.
- (4) The proposal of my organization is made in good faith and not pursuant to any agreement or discussion with, or inducement from, any firm or person to submit a complementary or other noncompetitive bid. I have read, understand, and will abide by the Authority's Contractor Integrity Provisions.
- (5) \_\_\_\_\_ (name of my organization) its affiliates, subsidiaries, officers, directors, members and employees are not currently under investigation by any governmental agency and have not in the last four years been convicted or found liable for any act prohibited by State or Federal law in any jurisdiction, involving conspiracy or collusion with respect to bidding on any public contract, except as follows: \_\_\_\_\_  
\_\_\_\_\_  
\_\_\_\_\_

I state that \_\_\_\_\_ (name of my organization) understands and acknowledges that the above representations are material and important and will be relied on by The Philadelphia Parking Authority when awarding the contract for which this proposal is submitted. I understand and my organization understands that any misstatement in this affidavit is and shall be treated as fraudulent concealment from The Philadelphia Parking Authority of the true facts relating to the submission of bids for this contract.

\_\_\_\_\_  
Authorized Signature

SWORN TO AND SUBSCRIBED

BEFORE ME THIS \_\_\_\_\_ DAY

OF \_\_\_\_\_ 2022.

\_\_\_\_\_  
Notary Public

My Commission Expires: \_\_\_\_\_

\_\_\_\_\_  
(Name of Bidder)

13. Bidder's Statement for Materials

13.1. The undersigned acknowledges furnishing and installing the products specified in the Project Manual for each type of work. The undersigned also acknowledges that his proposal is based on the cost of furnishing and installing the named products specified in the Project Manual and based on all materials to be American products made in the United States.

\_\_\_\_\_  
Authorized Signature

\_\_\_\_\_  
Print Name of Signer

\_\_\_\_\_  
Title of Signer

\_\_\_\_\_  
Date

13.2. The undersigned acknowledges that she/he will use the products listed below which he/she certifies are the equal of the named products specified in the Project Manual by the Owner and which he agrees, in accordance with the provisions of the Instructions to Bidders, will be permitted only if each proposed substitution has been approved in writing by the Owner prior to bid. The Owner reserves the sole right to approve original and verifiable quality control and standards of any and all materials used for this project. The undersigned confirms also that his proposal is based on the cost of furnishing and installing said approved products prior to bid as listed below:

Material: \_\_\_\_\_  
As Manufactured by: \_\_\_\_\_  
Is Proposed as the Equal of: \_\_\_\_\_  
And Has Been Approved by the Owner and the Architect on Addendum No.: \_\_\_\_\_

Material: \_\_\_\_\_  
As Manufactured by: \_\_\_\_\_  
Is Proposed as the Equal of: \_\_\_\_\_  
And Has Been Approved by the Owner and the Architect on Addendum No.: \_\_\_\_\_

Material: \_\_\_\_\_  
As Manufactured by: \_\_\_\_\_  
Is Proposed as the Equal of: \_\_\_\_\_  
And Has Been Approved by the Owner and the Architect on Addendum No.: \_\_\_\_\_

\_\_\_\_\_  
Signature of Owner or Partner

\_\_\_\_\_  
Name and Title of Signer

\_\_\_\_\_  
Name of Firm

\_\_\_\_\_  
Date

\_\_\_\_\_  
(Name of Bidder)

14. Bidder Qualification Form

14.1 Legal Name of Firm or Company: \_\_\_\_\_

Street Address \_\_\_\_\_

City \_\_\_\_\_ State \_\_\_\_\_ Zip \_\_\_\_\_

Phone Number: \_\_\_\_\_ Fax Number: \_\_\_\_\_

Email Address: \_\_\_\_\_

Website: \_\_\_\_\_

Contact Person: \_\_\_\_\_

Mobile Number: \_\_\_\_\_

14.2 Type of Business: (Check one)

Sole Proprietor

Date Company Started \_\_\_\_\_

Name of Owner \_\_\_\_\_

Street Address \_\_\_\_\_

City \_\_\_\_\_ State \_\_\_\_\_ Zip \_\_\_\_\_

Partnership (Attach list as needed)

Date of Partnership Agreement: \_\_\_\_\_

Name of Partner: \_\_\_\_\_

Street Address: \_\_\_\_\_

City \_\_\_\_\_ State \_\_\_\_\_ Zip \_\_\_\_\_

Name of Partner: \_\_\_\_\_

Street Address: \_\_\_\_\_

City \_\_\_\_\_ State \_\_\_\_\_ Zip \_\_\_\_\_

\_\_\_\_\_  
(Name of Bidder)

Limited Liability Company (Attach list as needed)

Date of Certificate of Formation: \_\_\_\_\_

Name of Managing Member: \_\_\_\_\_

Street Address: \_\_\_\_\_

City \_\_\_\_\_ State \_\_\_\_\_ Zip \_\_\_\_\_

Name of Member: \_\_\_\_\_

Street Address: \_\_\_\_\_

City \_\_\_\_\_ State \_\_\_\_\_ Zip \_\_\_\_\_

Corporation

Date of Incorporation: \_\_\_\_\_ State of Incorporation: \_\_\_\_\_

President: \_\_\_\_\_

Street Address: \_\_\_\_\_

City \_\_\_\_\_ State \_\_\_\_\_ Zip \_\_\_\_\_

Vice President: \_\_\_\_\_

Street Address: \_\_\_\_\_

City \_\_\_\_\_ State \_\_\_\_\_ Zip \_\_\_\_\_

Secretary: \_\_\_\_\_

Street Address: \_\_\_\_\_

City \_\_\_\_\_ State \_\_\_\_\_ Zip \_\_\_\_\_

Treasurer: \_\_\_\_\_

Street Address: \_\_\_\_\_

City \_\_\_\_\_ State \_\_\_\_\_ Zip \_\_\_\_\_



\_\_\_\_\_  
(Name of Bidder)

14.3 Federal Tax Identification Number (EIN): \_\_\_\_\_

14.4 Philadelphia Tax Account Number: \_\_\_\_\_

14.5 Philadelphia Commercial Activity License Number: \_\_\_\_\_

14.6 Philadelphia Contractor's Trade License Number: \_\_\_\_\_

14.7 Number of employees: (Check one)

Under 25       Under 50       Under 100       Over 100

14.8 Is your company a certified: (Check one)

MBE       WBE       DS-DBE

Certified by: \_\_\_\_\_

14.9 How many years of experience in this type of construction work does your organization have as a Prime Contractor? \_\_\_\_\_

14.10 On a separate sheet, list up to five similar projects your company *has completed* as a Prime Contractor in the past five years, giving the name of the project, Owner, Architect, contract amount, date of completion and percentage of the cost of the work performed by your own forces.

14.11 On a separate sheet, list up to five similar projects your company *has in progress* as a Prime Contractor, giving the name of the project, Owner, Architect, contract amount, percentage complete, scheduled completion date, and percentage of the cost of the work performed by your own forces.

14.12 List Bank Reference.

Bank Name: \_\_\_\_\_

Street Address: \_\_\_\_\_

City \_\_\_\_\_ State \_\_\_\_\_ Zip \_\_\_\_\_

Phone Number: \_\_\_\_\_ Fax Number: \_\_\_\_\_

Contact Person: \_\_\_\_\_

\_\_\_\_\_  
(Name of Bidder)

14.13 List Trade References:

Company Name: \_\_\_\_\_

Street Address: \_\_\_\_\_

City \_\_\_\_\_ State \_\_\_\_\_ Zip \_\_\_\_\_

Phone Number: \_\_\_\_\_ Fax Number: \_\_\_\_\_

Contact Person: \_\_\_\_\_

Company Name: \_\_\_\_\_

Street Address: \_\_\_\_\_

City \_\_\_\_\_ State \_\_\_\_\_ Zip \_\_\_\_\_

Phone Number: \_\_\_\_\_ Fax Number: \_\_\_\_\_

Contact Person: \_\_\_\_\_

Company Name: \_\_\_\_\_

Street Address: \_\_\_\_\_

City \_\_\_\_\_ State \_\_\_\_\_ Zip \_\_\_\_\_

Phone Number: \_\_\_\_\_ Fax Number: \_\_\_\_\_

Contact Person: \_\_\_\_\_

Company Name: \_\_\_\_\_

Street Address: \_\_\_\_\_

City \_\_\_\_\_ State \_\_\_\_\_ Zip \_\_\_\_\_

Phone Number: \_\_\_\_\_ Fax Number: \_\_\_\_\_

Contact Person: \_\_\_\_\_

14.14 List the equipment available for the performance of work under the proposed contract (use a separate sheet if necessary):

\_\_\_\_\_  
\_\_\_\_\_  
\_\_\_\_\_

\_\_\_\_\_  
 (Name of Bidder)

14.15 List any Unions that you have agreements with. If none, write "none."

Local Number	Union Name	Agreement Expiration
_____	_____	_____
_____	_____	_____
_____	_____	_____

14.16 Certified Apprenticeship Program Participation

Bidders must be currently participating in an approved Apprenticeship Program which is currently registered with the U.S. Department of Labor or a state apprenticeship agency for each craft or trade that will be engaged in the Work. Bidders shall employ apprentices whose training and employment are in full compliance with the Apprenticeship and Training Act, approved July 14, 1961.

1) Does Bidder participate in an approved Apprenticeship Program which is currently registered with the U.S. Department of Labor or a state apprenticeship agency for each craft or trade that will be engaged in the Work? (Attach appropriate documents evidencing participation and enrollment in Apprenticeship Program[s])

Yes       No

2) Is Bidder a signatory to a collective bargaining agreement for each craft or trade that will be engaged in the Work? (Attach appropriate documents evidencing the relevant agreement[s])

Yes       No

*If Bidder answered "Yes" to questions 1 or 2, please answer question 3 (including sub-parts) below.*

3) Does Bidder, or its labor for each craft or trade, have apprentices and trainees currently participating in said Apprenticeship Program[s]?

Yes       No

(a) If yes, has Bidder, or its labor for each craft or trade, graduated at least one (1) enrollee in each of the past three (3) years? (Graduation rate is calculated by dividing graduates in a calendar year by the number of enrollees in that year.)

Yes       No

(b) If yes, has Bidder (or its labor for each craft or trade) successfully graduated at least 75% of the program enrollees in each of the past three (3) years\*? (Graduation rate is calculated by dividing graduates in a calendar year by the number of enrollees in that year.)

Yes       No

The Undersigned hereby certifies that it participates, directly or through its labor for each craft or trade, in an approved Apprenticeship Program which is currently registered with the U.S.

\_\_\_\_\_  
(Name of Bidder)

Department of Labor or a state apprenticeship agency for each craft or trade that will be engaged in the Work; that the attached documentation is true and correct proof of its current participation; and will continue to participate in applicable apprenticeship programs for each craft or trade for the full duration of the Work.

\_\_\_\_\_  
Authorized Signature

\_\_\_\_\_  
Print Name of Signer

\_\_\_\_\_  
Title of Signer

\_\_\_\_\_  
Date

14.17 If "yes" is checked to any of the following questions, applicable within the past five (5) years, please provide a summary and details.

- 1) Has your company ever defaulted or been terminated on a contract?  
 Yes     No
- 2) Has your company ever had a claim made against it for improper, delayed, or non-compliant work or failure to meet warranty obligations?  
 Yes     No
- 3) Has your company or any of its principals ever petitioned for bankruptcy or failed in business?  
 Yes     No
- 4) Have any of the Owners, Officers, or Major Stockholders of your company ever been indicted or convicted of any felony or other criminal conduct?  
 Yes     No
- 5) Has your company ever been banned or otherwise precluded from pursuing public work or have ever been found to be non-responsive by a public agency?  
 Yes     No
- 6) Is your company or any of its Owners, Officers, or Major Stockholders currently involved in any arbitration or litigation?  
 Yes     No
- 7) Does your company have any outstanding judgments or claims against it?  
 Yes     No
- 8) Has any litigation been brought against your company asserting that you failed to make payments to anyone?  
 Yes     No

\_\_\_\_\_  
(Name of Bidder)

15. Financial Statements

15.1 Certified Public Accountant Firm \_\_\_\_\_

Company Name: \_\_\_\_\_

Street Address: \_\_\_\_\_

City \_\_\_\_\_ State \_\_\_\_\_ Zip \_\_\_\_\_

Phone Number: \_\_\_\_\_ Fax Number: \_\_\_\_\_

Contact Person: \_\_\_\_\_

15.2 Attach Financial Statements, for the last three (3) years, which have been audited or reviewed by an independent Certified Public Accountant who is not an employee of the Bidder.

Are the attached Financial Statements for the identical organization named on page one of this Bid Form?

\_\_\_\_ Yes      \_\_\_\_ No

If not, explain the relationship and the fiscal responsibility of the organization whose Financial Statements are provided (e.g., parent or subsidiary).

\_\_\_\_\_  
\_\_\_\_\_  
\_\_\_\_\_  
\_\_\_\_\_  
\_\_\_\_\_  
\_\_\_\_\_

END OF SECTION 004100

NO.	DATE	REVISIONS
2	6/8/22	ADDENDUM 2
1	5/4/22	FINAL REVIEW

DESIGN:	EM
DRAWN:	EM
CHECKED:	AW
SCALE:	AS SHOWN
DATE:	04/13/2022

DRAWING TITLE:  
**FLOOR PLANS**

DRAWING No.

**A-101**

PRE-MANUFACTURED TRAILER  
 DATE OF MANUFACTURE: 11/2/2020  
 FLOOR LIVE LOAD: 50 psf  
 ROOF LIVE LOAD: 20/30 gsf  
 SEISMIC DESIGN CATEGORY: B  
 CONSTRUCTION TYPE: V-B  
 FIRE RATING OF EXT. WALLS: 0  
 UNIT CONSTRUCTED IN COMPLIANCE WITH:  
 2018 IBC W/AMENDMENTS;  
 2018 PHILADELPHIA FIRE CODE;  
 2017 NEC;  
 2018 IPC;  
 2018 IMC;  
 ICC/ANSI A117.7-2009;  
 2018 IECC W/AMENDMENTS  
 THERMAL TRANSMIT (U-FACTOR)  
 FLOOR: R=30, WALLS: R=21, ROOF/CEILING: R=60

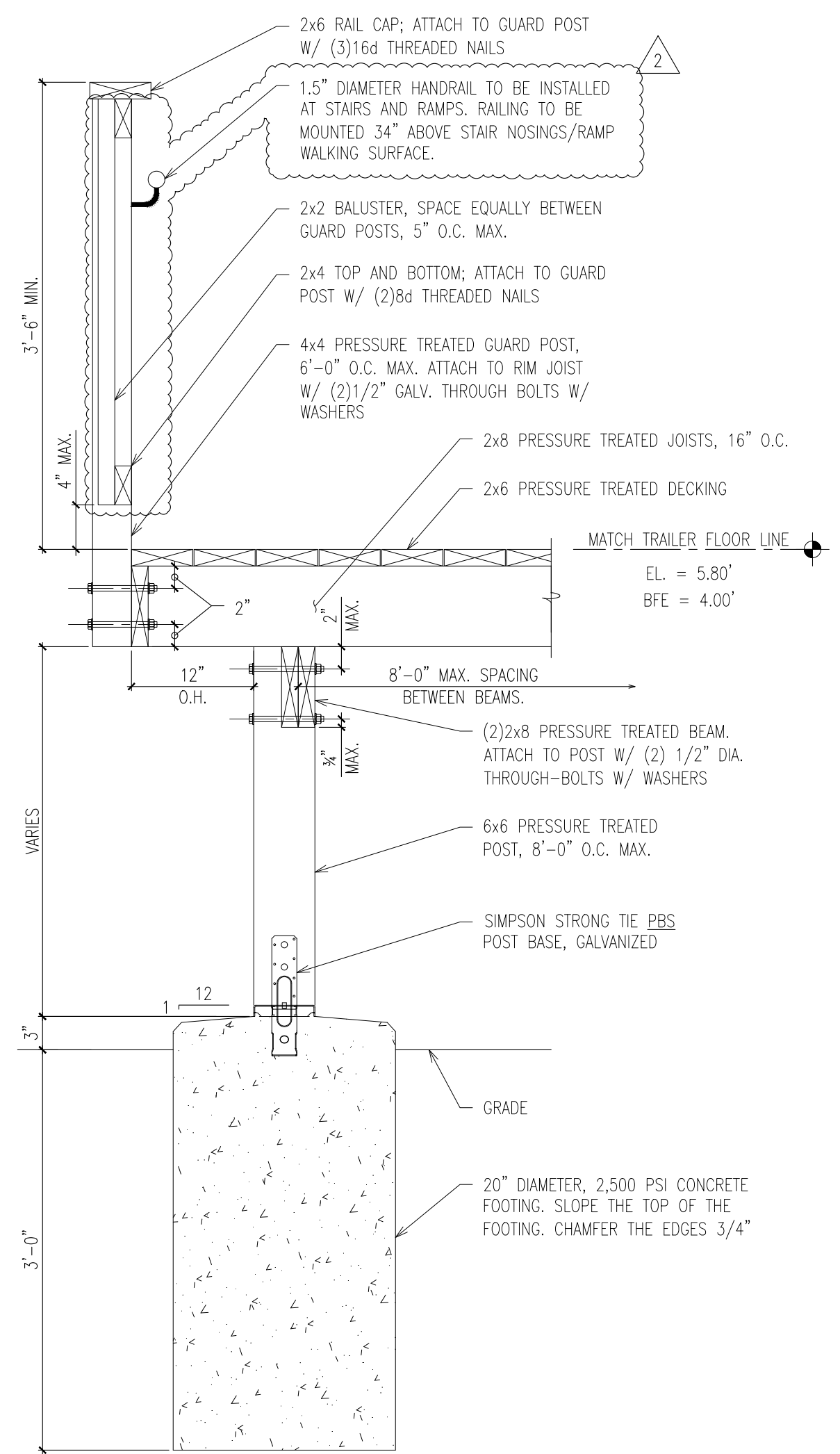
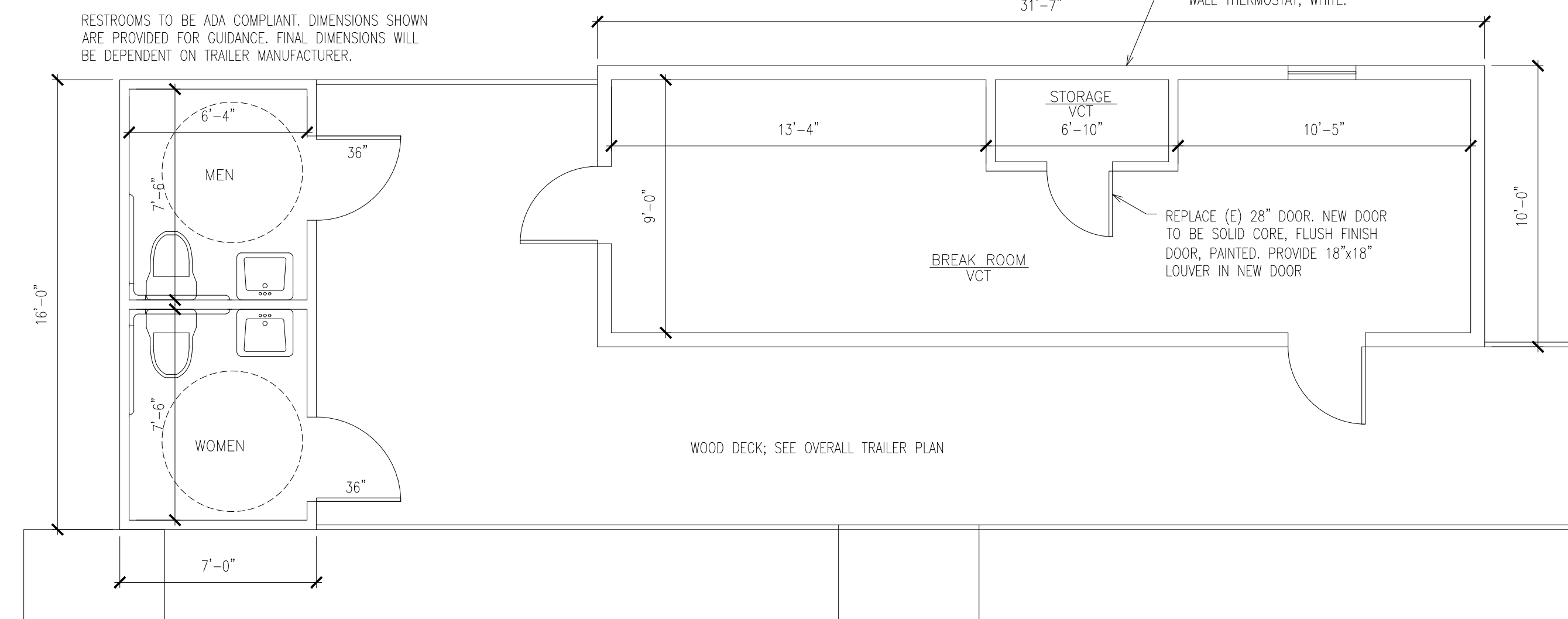
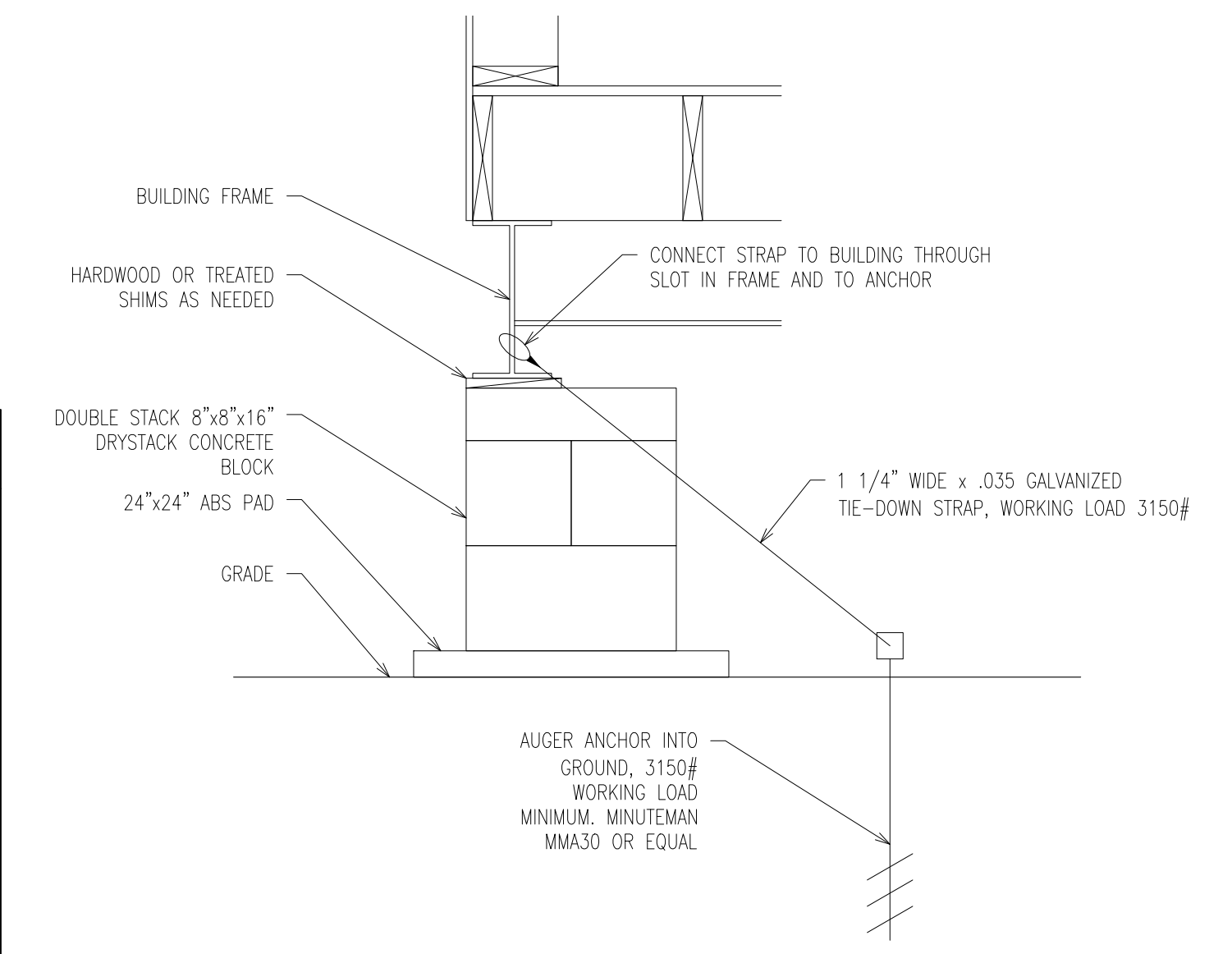
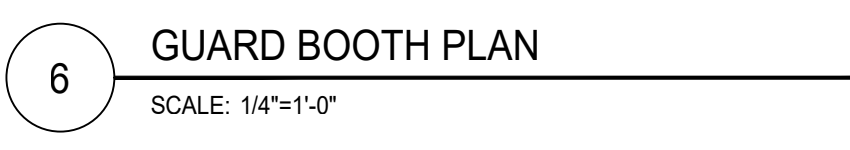
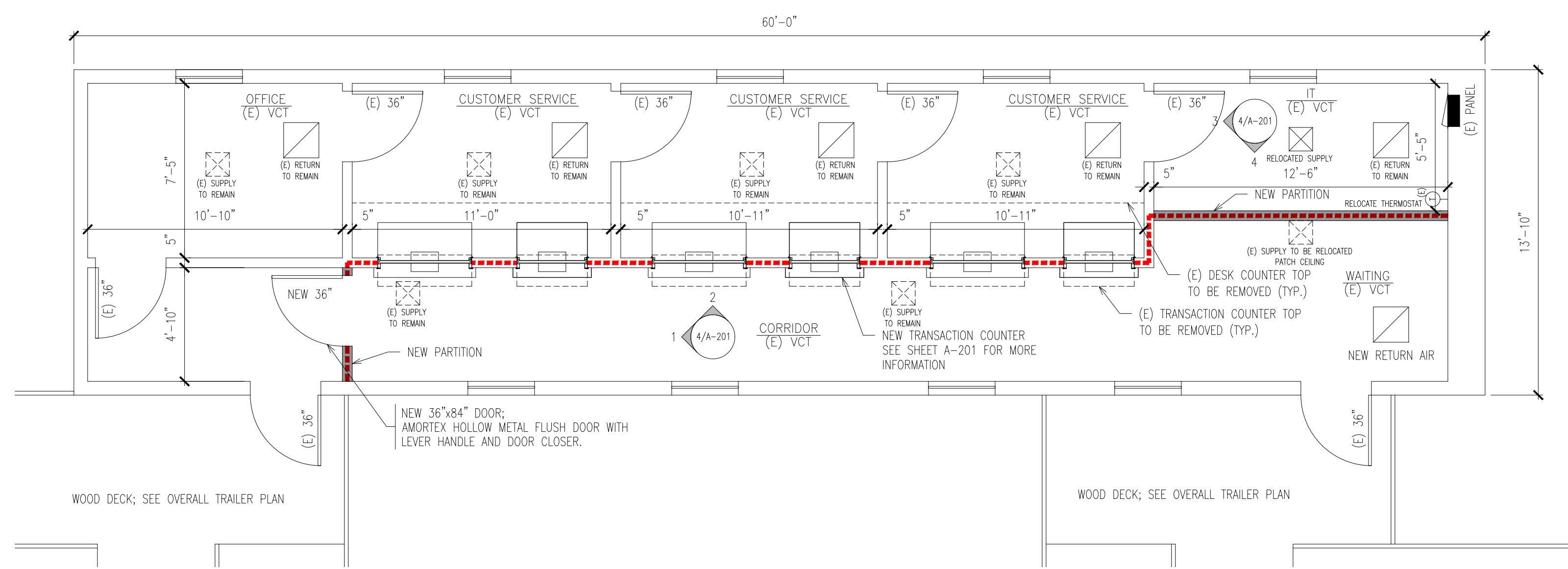
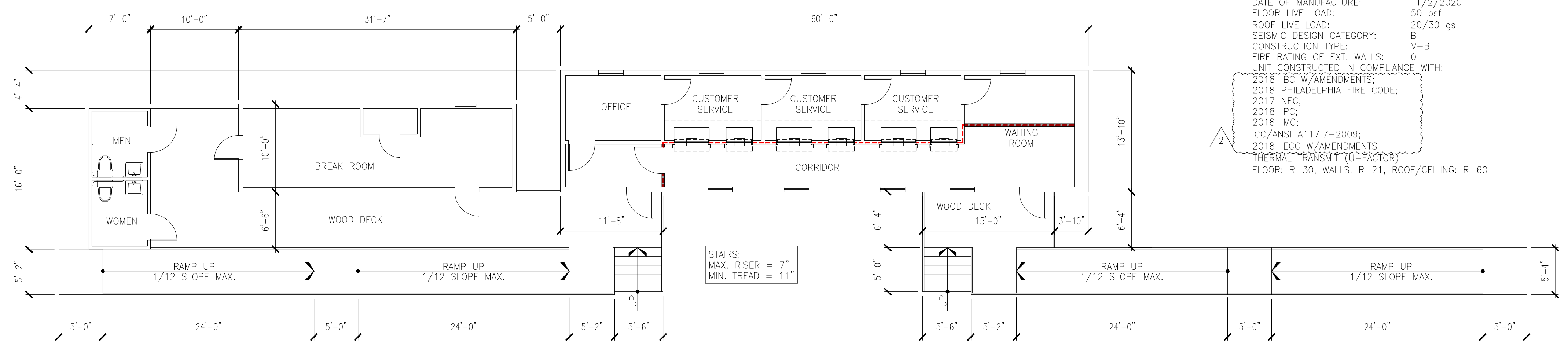

NOTE:  
 RAILING TO BE PVC COATED ALUMINUM. PROVIDE ALL ACCESSORIES TO MOUNT THE HANDRAILS AT THEIR RESPECTIVE LOCATIONS. ATTACH RAILING TO EACH GUARD POST, NOT TO EXCEED 72" MAX. ACCESSORIES TO INCLUDE, BUT NOT LIMITED TO; END CAPS, MOUNTING BRACKETS, RAIL JOINER, AND RETURNS

Dedicated Space for City Department Approval Stamps